

Conductive Level Switch for Liquids



measuring
•
monitoring
•
analyzing

NE-Series



- Multiple Setpoints Available
- Compatible with Corrosive Media
- Compatible with Dirty Media
- Highly Reliable
- Rigid Probe or Cable Versions
- Discrete Alarms or Latching Pump or Valve Control



KOBOLD companies worldwide:

AUSTRALIA, AUSTRIA, BELGIUM, BULGARIA, CANADA, CHINA, CZECHIA, FRANCE, GERMANY, GREAT BRITAIN, HUNGARY, INDIA, INDONESIA, ITALY, MALAYSIA, MEXICO, NETHERLANDS, PERU, POLAND, REPUBLIC OF KOREA, RUSSIA, SPAIN, SWITZERLAND, THAILAND, TUNISIA, TURKEY, USA, VIETNAM

KOBOLD Instruments, Inc.
1801 Parkway View Drive
Pittsburgh, PA 15205
Main Office:
1.800.998.1020
1.412.788.4890
info@koboldusa.com
www.koboldusa.com

Description

The KOBOLD NE-Series can be used to monitor the level of liquids with a minimum conductivity of 20 $\mu\text{S}/\text{cm}$. The device works by measuring the electrical resistance between a sensing electrode and a ground reference. Because the design has no moving parts, it handles difficult media; such as low density liquids, high viscosity liquids, or liquids with large quantities of particulates. It is available in a wide range of materials with electrodes in 316-Ti stainless steel, Hastelloy[®]C, or titanium. With compatible wetted parts, even concentrated acids may be measured. Up to six electrodes are available on the NE-Series, making a total of six set-points possible. A complete NE-Series level switch system consists of a ground reference, a sensing electrode, and a relay/power supply.

Ground Referencing Electrode

The basic NE can monitor a single set-point by utilizing a single sensing electrode, if an electrically conductive container is used as a ground reference. The system is grounded via the stainless steel process fitting or by using a direct wire connection from the tank wall to the power supply relay. If the container is not conductive or uses a polypropylene or PTFE fitting, the second electrode is necessary for a ground reference. For all applications, a grounding reference electrode is recommended.

Sensing Electrode

One electrode is required per sensing point. The length of the electrode or cable depends on the desired sensing point. To avoid electrical bridging, most of the electrode options are fully coated with a non-conductive cladding. The cladding is a complete coating which only leaves the last 1/4 inch exposed. Completely coated electrodes assure proper monitoring, even in the presence of mist formation and impure media.

Electrode Relay/Power Supply

Operation requires one relay channel per function, alarm, or latch control. Two setpoint electrodes and a ground electrode must be connected to the relay unit to provide automatic control, such as latching tank fill and empty. The relay/power supply is available in either single or dual channel versions.

Single Rigid Electrode



Single Suspended Electrode



Multipoint Rigid Electrodes

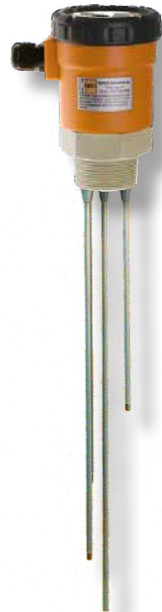

Multipoint Suspended Electrodes





Single Rigid Electrode Models

Housing Materials:	Polycarbonate or Aluminum	Min. Rod Length: 2"
Fitting:	1/2" NPT	Max. Rod Length
Max. Temperature		SS: 120"
Polyolefin Cladding:	190 °F	Titanium: 118"
PTFE Cladding:	300 °F	Hastelloy®: 60"
With PP Fittings:	190 °F	Max. Pressure
Protection:	IP 65	PP Fitting: 220 PSIG
		PTFE Fitting: 90 PSIG
		SS Fitting: 440 PSIG

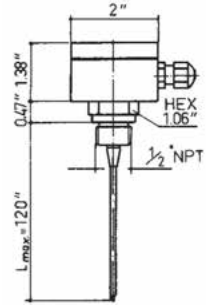

Order Details: (Example: NEL-1EAP L=24")

Model	Housing	Electrode Quantity	Electrode Material	Electrode Cladding	Fitting Material	Electrode Length
NE..	..K- = Polycarbonate 1.38" x 2.05" x 1.97" ..L- = Aluminum 1.38" x 2.05" x 1.97"	1.. = One	..E.. = Stainless Steel ..H ²⁾ .. = Hastelloy®C ..T ²⁾ .. = Titanium	..A.. = Polyolefin ..T.. = PTFE Partially-Clad (to 12") ..V.. = PTFE Fully-Clad	..P ¹⁾³⁾ = PP ..E = Stainless Steel ..F ²⁾ = PTFE	When Ordering Please Specify Length: L = _____"

1) Only with Stainless Steel Electrodes 2) Not with Polyolefin Cladding 3) Only with Polyolefin Cladding

Multipoint Rigid Electrode Models

Housing Materials:	Polyamide or Aluminum	Min. Rod Length: 2"
Fitting:	1-1/2" NPT	Max. Rod Length
Max. Temperature		SS: 120"
Polyolefin Cladding:	190 °F	Titanium: 118"
PTFE Cladding:	300 °F	Hastelloy®: 60"
With PP Fittings:	190 °F	Max. Pressure
Protection:	IP 65	PP Fitting: 220 PSIG
		PTFE Fitting: 90 PSIG
		SS Fitting: 440 PSIG

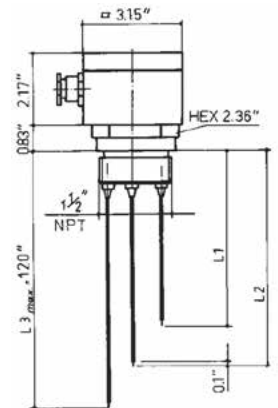

Order Details: (Example: NEL-2EAP L=24" L2=36")

Model	Housing	Electrode Quantity	Electrode Material	Electrode Cladding	Fitting Material	Electrode Lengths
NE..	..L- = Aluminum 2.17" x 3.15" x 2.95" ..K- = Polyamide 1.38" x 2.05" x 1.97"	2.. = Two 3.. = Three 4.. = Four 5.. = Five 6.. = Six	..E.. = Stainless Steel ..H ²⁾ .. = Hastelloy®C ..T ²⁾ .. = Titanium	..A.. = Polyolefin ..T.. = PTFE Partially-Clad (to 12") ..V.. = PTFE Fully-Clad	..P ¹⁾³⁾ = PP ..E = Stainless Steel ..F ²⁾ = PTFE	When Ordering: Please Specify Length L1 = _____" (shortest) L2 = _____" ...etc (to longest)

1) Only with Stainless Steel Electrodes 2) Not with Polyolefin Cladding 3) Only with Polyolefin Cladding



Single Suspended Electrode Models

Housing Materials: Polycarbonate, Aluminum
Fitting: 1/2" NPT
Max. Temperature
 Neoprene* Cable: 140 °F
 PTFE Cable: 300 °F

Max. Cable Length
 Neoprene*: 100 feet
 PTFE: 30 feet
Max. Pressure: 90 PSIG
Protection with Housing: IP 65

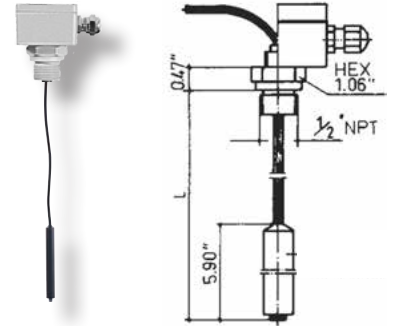

Order Details: (Example: NEH-1HVK L=24")

Model	Electrode Quantity	Electrode Material	Cable Cladding	Fitting Material	Housing Type	Electrode Length
NEH-	1.. = One	..E.. = Stainless Steel ..H ²⁾ .. = Hastelloy®C ..T ²⁾ .. = Titanium	..N.. = Neoprene* Ø 0.23" ..V.. = PTFE Ø 0.08"	..P ¹⁾³⁾ .. = PP ..F ²⁾ .. = PTFE	..K = Polycarbonate 1.38" x 2.05" x 1.97" ..L = Aluminum 1.38" x 2.05" x 1.97" ..0 = Without (With 2 m Cable)	When Ordering: Please Specify Length L = ____ "

1) Only with Stainless Steel Electrodes 2) Only with PTFE Cladding 3) Only with Neoprene* Cladding

* Material specification: rubber cladding according to HARH07RN-F standard, approval according to EN-50525-2-21

Multipoint Suspended Electrodes Models

Housing Materials: Polyamide, Aluminum
Fitting: 1-1/2" NPT
Max. Temperature
 Neoprene* Cable: 140 °F
 PTFE Cable: 300 °F

Max. Cable Length
 Neoprene*: 100 feet
 PTFE: 30 feet
Max. Pressure: 90 PSIG
Protection with Housing: IP 65

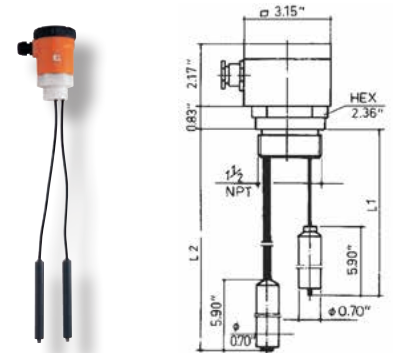

Order Details: (Example: NEH-3ENPK L1=24", L2=48"...etc)

Model	Electrode Quantity	Electrode Material	Cable Cladding	Fitting Material	Housing Type	Electrode Lengths
NEH-	2.. = Two 3.. = Three 4.. = Four 5.. = Five 6.. = Six	..E.. = Stainless Steel ..H ²⁾ .. = Hastelloy®C ..T ²⁾ .. = Titanium	..N.. = Neoprene* Ø 0.23" ..V.. = PTFE Ø 0.08"	..P ¹⁾³⁾ .. = PP ..F ²⁾ .. = PTFE	..K = Polycarbonate 1.38" x 2.05" x 1.97" ..L = Aluminum 1.38" x 2.05" x 1.97" ..0 = Without (With 2 m Cable)	When Ordering: Please Specify Length L1 = ____ " (shortest) L2 = ____ "...etc (to longest)

1) Only with Stainless Steel Electrodes 2) Only with PTFE Cladding 3) Only with Neoprene* Cladding

* Material specification: rubber cladding according to HARH07RN-F standard, approval according to EN-50525-2-21

Electrode Relay/Power Supply

The NE level switch is powered by the NE-104x/304x relay/power supply. These provide a maximum or minimum set-point signal for use in controlling liquid levels. The NE-104 is a single channel controller and the NE-304 has two independent control channels.



Technical Details: NE-104x, Single Control Channel

- Power Supply:** 230 V_{AC}, 110 V_{AC},
24 V_{AC} ±15%, 50-60 Hz
- Power Consumption:** 2 VA
- Max. Electrode Voltage:** 10 V_{AC}
- Max. Electrode Current:** 0.5 mA
- Sensitivity (Adjustable):** 0-50 kΩ
- Response Time:** Approx. 1 Second
- Ambient Op. Temp:** -4...140 °F
- Output:** 1 SPDT Relay
Max. 250 V_{AC}
@ 5 A, 600 VA
- Enclosure:** IP40, Makrolon®
- Terminals:** IP 20
- Installation:** Rail Mountability
for DIN 46121 Rail

Technical Details: NE-304x, Dual Control Channels

- Power Supply:** 230 V_{AC}, 110 V_{AC},
24 V_{AC} ±15%, 50-60 Hz
- Power Consumption:** 4 VA
- Max. Electrode Voltage:** 10 V_{AC}
- Max. Electrode Current:** 0.5 mA
- Sensitivity (Adjustable):** 0-50 kΩ
- Response Time:** Approx. 1 Second
- Ambient Op. Temp:** -4...140 °F
- Output:** 2 SPDT Relay
Max. 250 V_{AC}
@ 5 A, 600 VA
- Enclosure:** IP40, Makrolon®
- Terminals:** IP 20
- Installation:** Rail Mountability
for DIN 46121 Rail

Dimensions

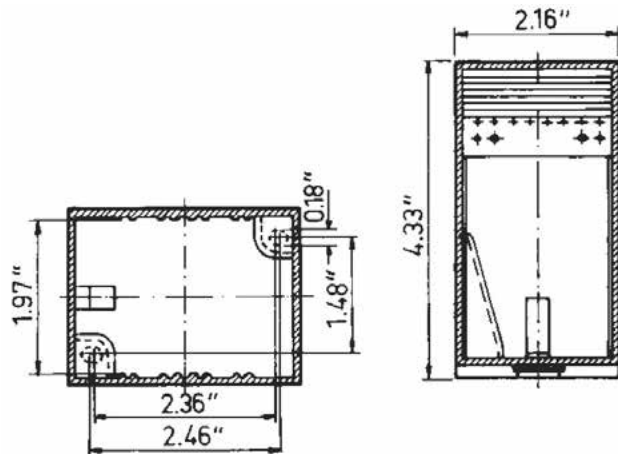

Order Details: (Example: **NE-1041**)

Power Supply	Number of Control Channels	
	1 Channel	2 Channels
230 VAC	NE-1040	NE-3040
110 VAC	NE-1041	NE-3041
24 VAC	NE-1042	NE-3042

Functionality Diagrams

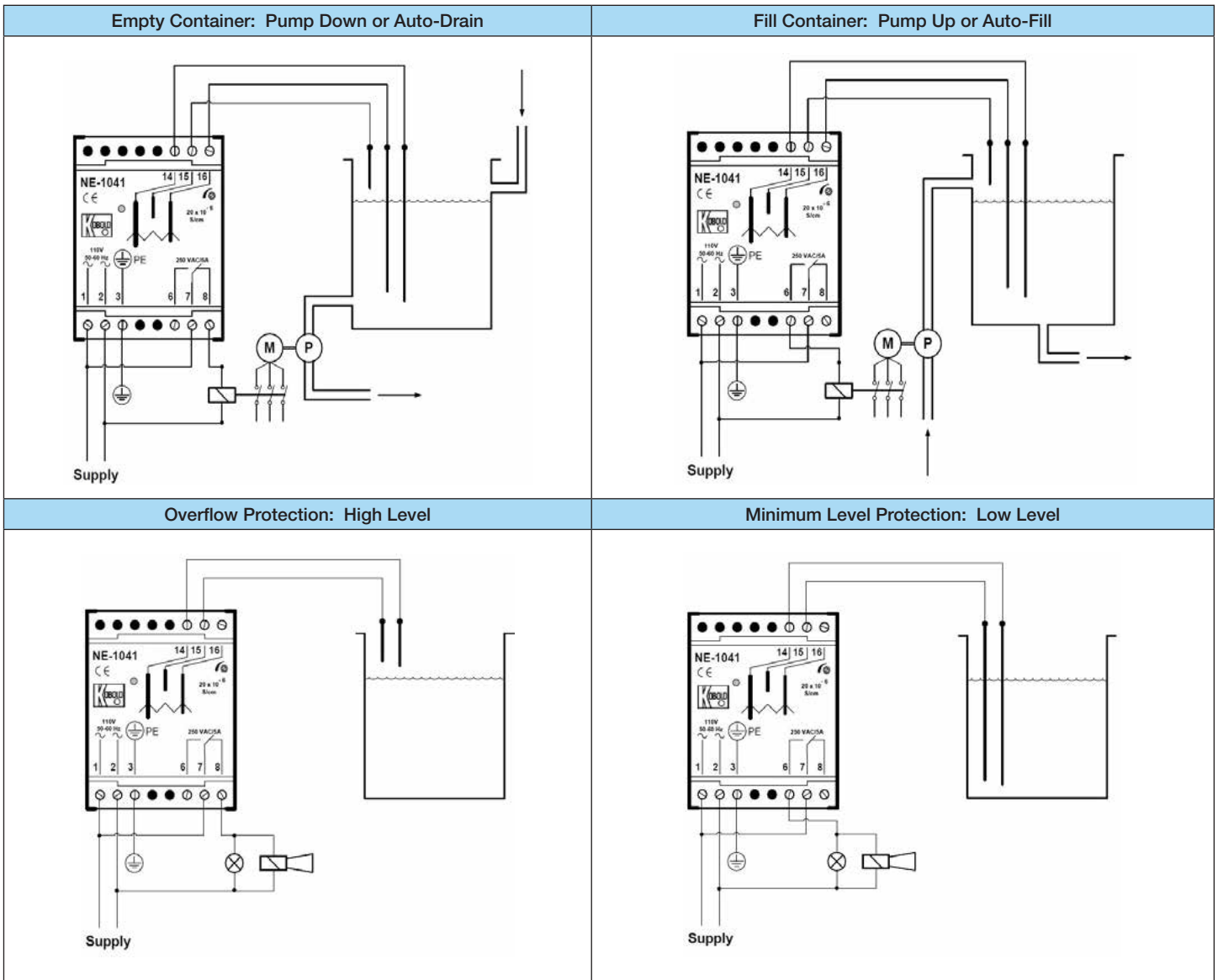

Note

The ground electrode at terminal 14 may be omitted if the container wall is conductive. Terminal 14 may then be connected directly to the container wall.